

MAIN MARK	GRID LOCATION
16C1	E/4

BILL OF MATERIAL - JOB# 05-4870

DERRICK					SHIP MARK	PIECE MARK	QUAN.	DESCRIPTION	LENGTH	GRADE	FINISH	WEIGHT	NOTES
1	2	3	4	5									
1	0	0	0	0	16C1	16C1	1	W12X210	38'-4 1/2"	A992		8070.8	SC-2E
						b10	1	PL2 X16	2'-2"	A572-50		236	
						b11	2	PL1 1/4X9	2'-4"	A572-50	NO PAINT	89.5	
						c11	1	PL3/8X3 1/2	1'-6"	A572-50	NO PAINT	6.7	
						c12	4	PL7/8X7	1'-4"	A572-50	NO PAINT	27.8	
						d10	1	PL3/8X3 1/2	2'-0"	A572-50	NO PAINT	8.9	
						d12	2	PL3/8X3 1/2	1'-0"	A572-50	NO PAINT	4.5	
						e10	2	PL1 1/8X9	2'-7"	A572-50	NO PAINT	89.1	
						f10	2	PL1 X14	2'-10"	A572-50		135	
						g10	2	PL3/8X7 1/2	0'-9"	A572-50		7.2	

TOTAL QTY.	FIELD BOLTS	MAIN MARK	LENGTH
3	3/4" DIA. A325N-DTI	16C1	3 1/2"
16	1" DIA. A490X-DTI	16C1	4 3/4"

BOLT TYPE SCHEDULE  
 A325N = BOLT TO INCLUDE 1 HEX NUT & 1 STANDARD FLAT WASHER  
 A325N-2W = BOLT TO INCLUDE 1 HEX NUT & 2 STANDARD FLAT WASHERS  
 A325N-DTI = BOLT TO INCLUDE 1 HEX NUT, 1 STANDARD FLAT WASHER, & 1 LOAD INDICATOR WASHER

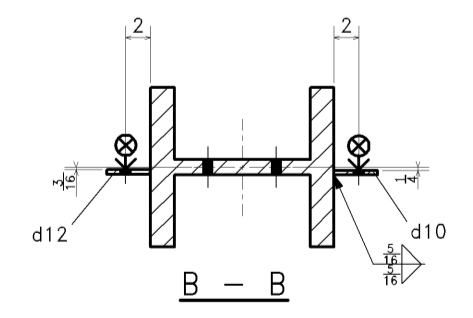
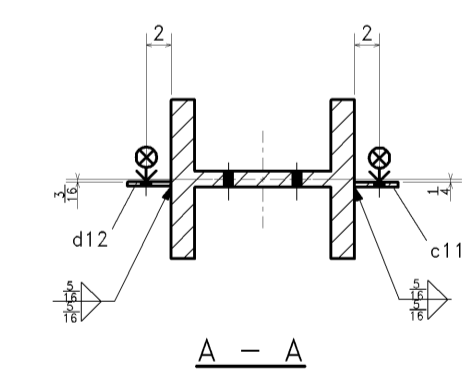
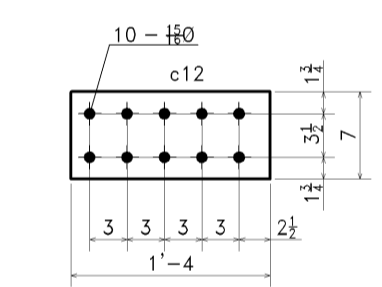
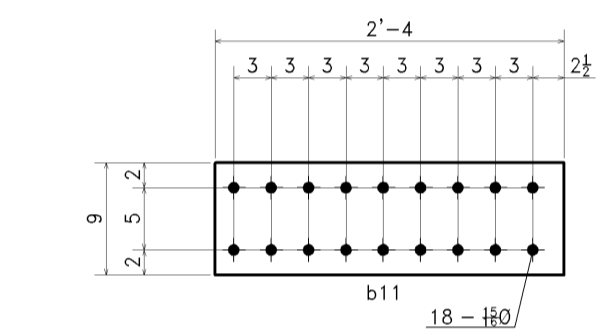
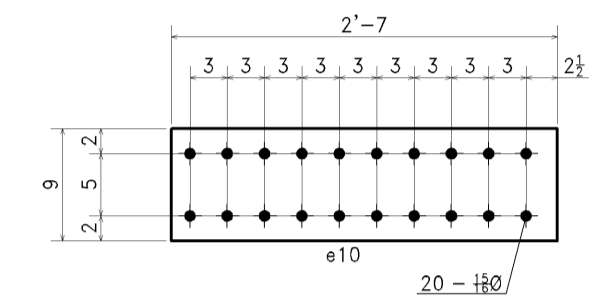
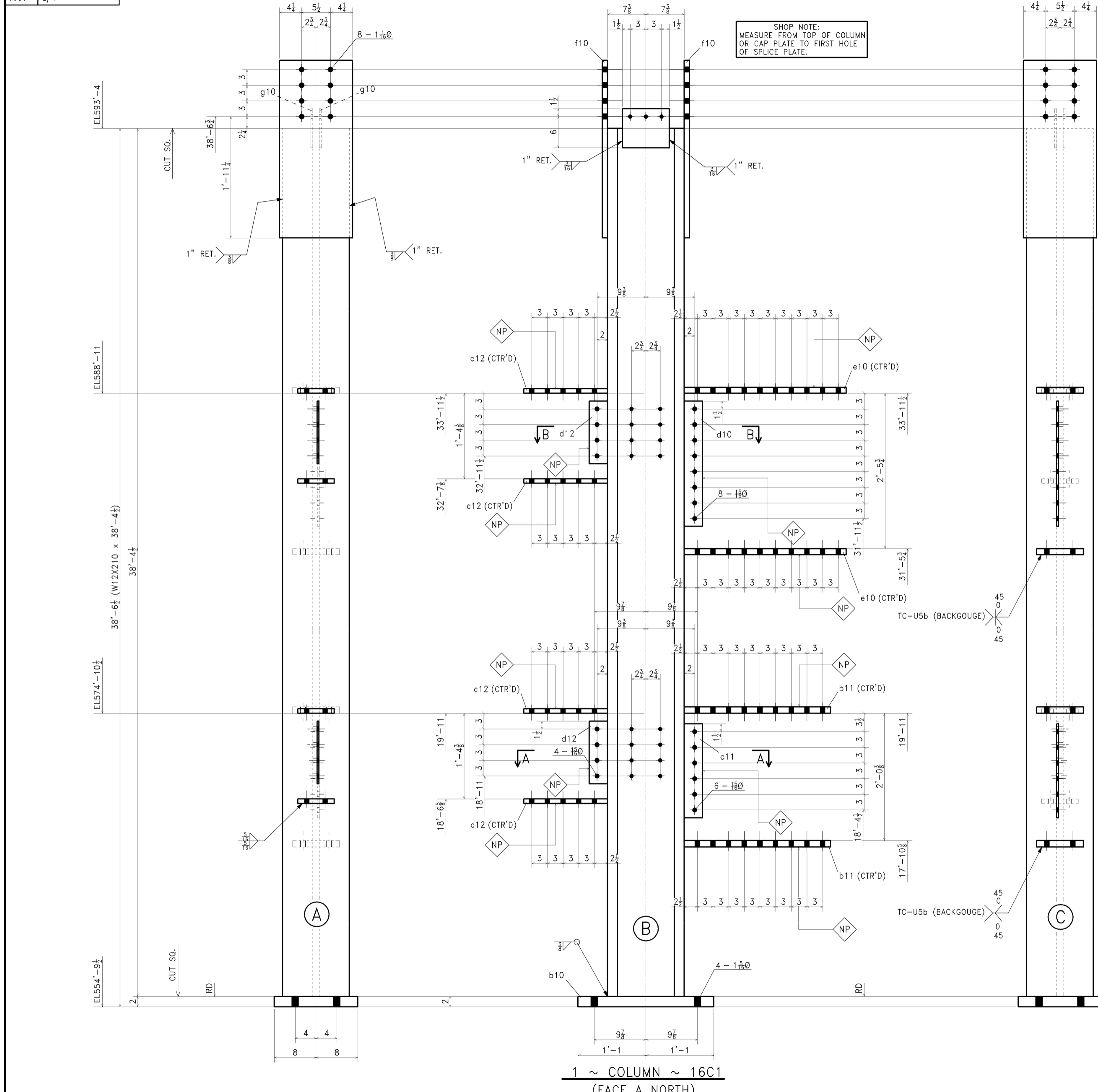

NP DENOTES HOLES FOR SLIP CRITICAL TYPE BOLTS  
 NO PAINT, OIL OR LACQUER WITHIN 3" OF OPEN HOLES

HOLE SIZE: 13/16" U.N.O.	NO.	DATE	BY	REVISIONS
SURFACE PREP: SSPC-SP3	1	08/15/2005		DESCRIPTION
PAINT: 1 S/C SW GREY B-50				PER APPROVAL / CHECKING

ERECTOR'S NOTE  
 STEEL IS FABRICATED WITH "ERECTOR MARKS" ON LEFT HAND END OF MEMBERS. STEEL MUST BE ERECTED WITH "ERECTOR MARKS" WORKWISE AND IN POSITION SHOWN ON ERECTION PLAN.

**HUNTINGTON STEEL**  
 100 3RD AVENUE HUNTINGTON, WEST VIRGINIA

WORK ORDER NO. 05-4870  
 CUST. ORDER NO.  
 SCALE:

DRAWN BY: J.B. LONG  
 CHK'D. BY: VAS 07/26/2005  
 DATE: 07/06/2005

SHEET NUMBER: 16 OF  
 TITLE: CLINICAL EDUCATION AND OUTREACH CENTER  
 MARSHALL UNIVERSITY - JOAN C. EDWARDS SCHOOL OF MEDICINE  
 HUNTINGTON, WEST VIRGINIA  
 CUSTOMER: J & H ERECTORS, INC.