

← N — PLATFORM FRAMING PLAN @ EL/ 593'-0

1. TOP OF STEEL ELEVATION IS 593'-0 U.N.O.
2. TOP OF STEEL NOTED AS (+/- xx) IS REFERENCED FROM ELEV. 593'-0 .
3. ● INDICATES MEMBER DIRECTION MARK.
4. FOR BRACE DETAIL SEE F6.

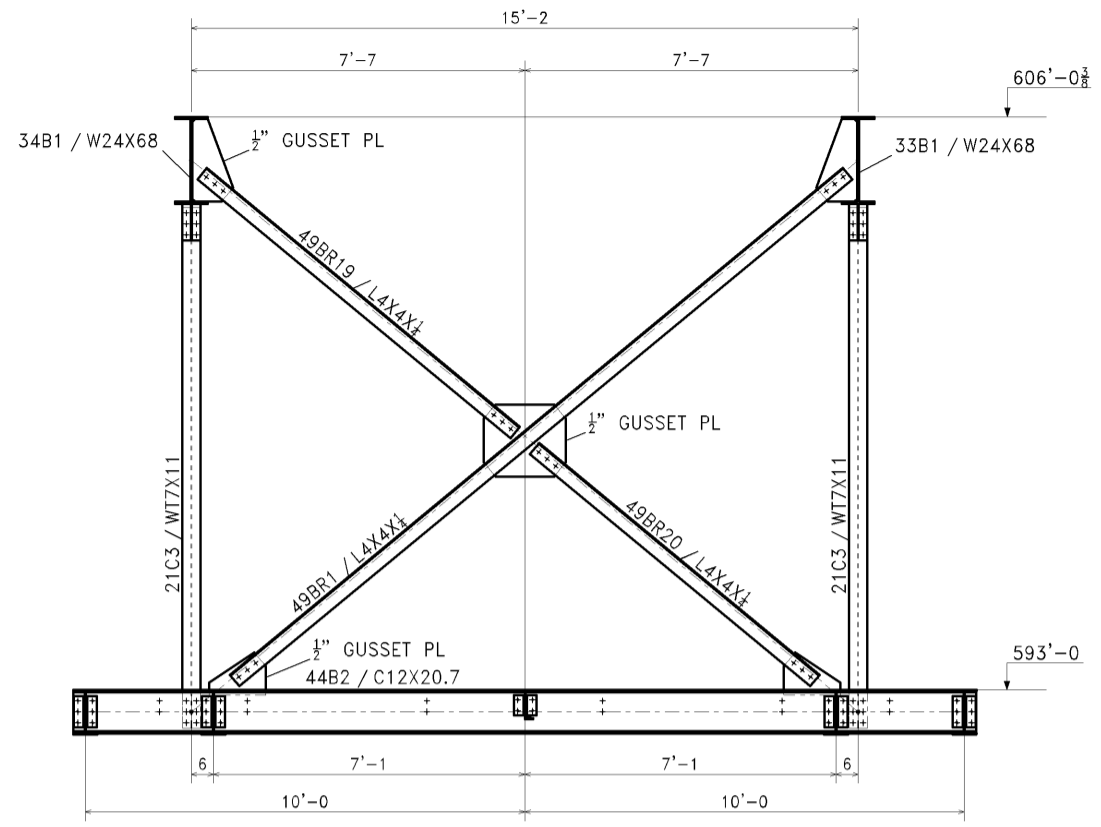

HORIZONTAL BRACING NOT SHOWN FOR CLARITY
SECTION-A-A

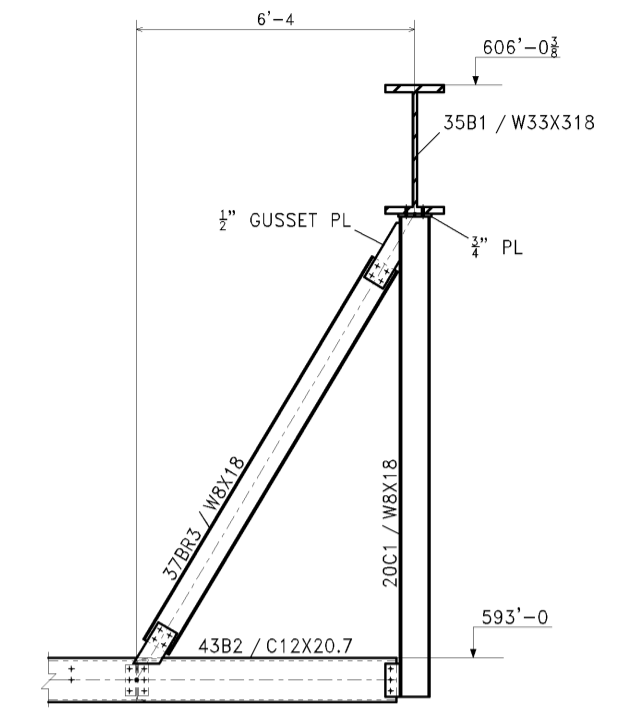

SECTION-B-B

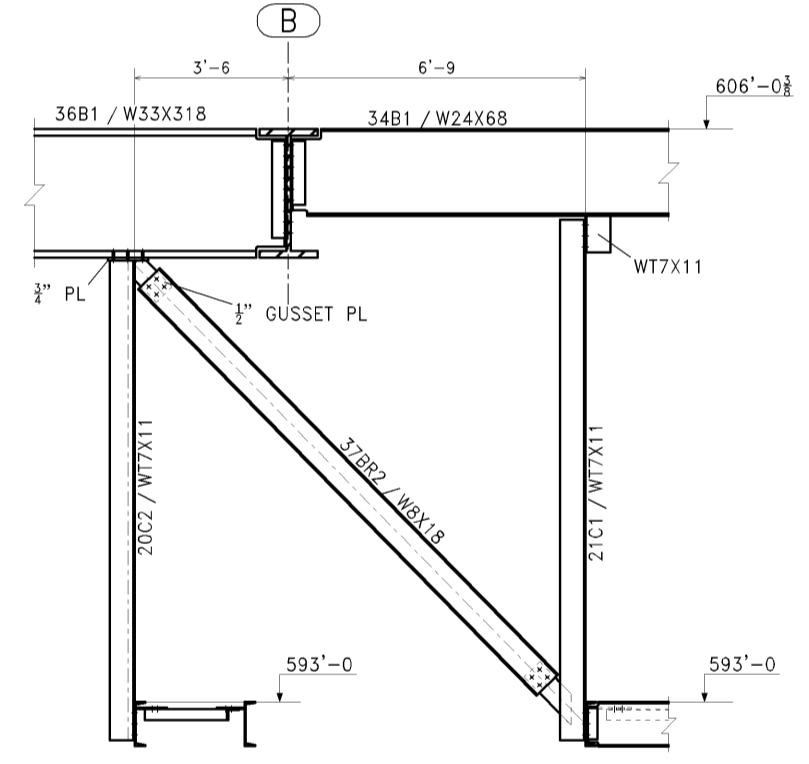

SECTION-D-D

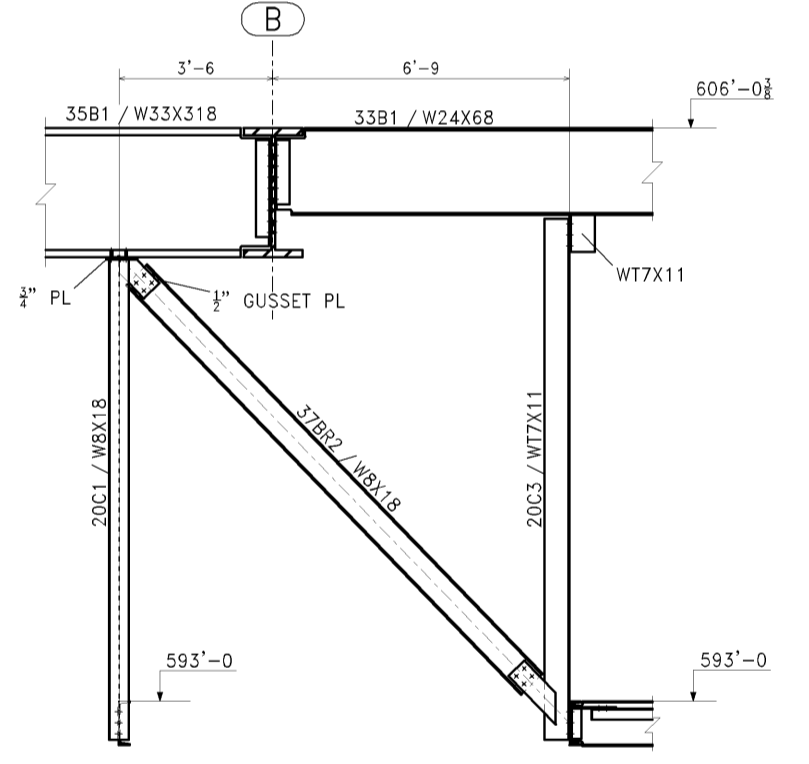

SECTION-C-C

ALL BOLTS TO BE GALVANIZED
ALL ROLLED SHAPES TO BE A992

ALL STEEL PAINTED PER SPECS			
GENERAL NOTES:			
MAT'L	-	ASTM A36 U.N.O.	
TUBING	-	ASTM A500, GR. B	
PIPE	-	ASTM A53, GR. B	
BOLTS	-	1/2" DIA. A-325 U.N.O.	
HOLES	-	1/2" DIA. U.N.O.	
WELD	-	E70XX ELECTRODES (LOW HYDROGEN FOR GRADE 50 STEEL)	
SURFACE PREP - PER SPECS			
TOLERANCES AS NOTED UNLESS OTHERWISE SPECIFIED			
FRACTIONAL ± 1/64	0	± 0.05"	± 1.27mm
0	± 0.05"	± 0.005"	± 0.127mm
ANGLES ± 1/2°			
BREAK ALL SHARP CORNERS			
<input type="checkbox"/>	STRESS RELIEVE		
<input type="checkbox"/>	STRAIGHTNESS		
<input type="checkbox"/>	ROUNDNESS		

REV.	DATE	PER APPROVAL & CHECKING	DESCRIPTION	JBL	BY
0	1/19/05				

Smithahn Company
836 E. NORTH STREET
P.O. BOX 679
BETHLEHEM, PA 18016
Office: 610/866-4461 Fax: 610/867-5246

DESCRIPTION: PREHEATER TOWER MODIFICATIONS
STEEL ARRANGEMENT DRAWING, SECTIONS AND DETAILS

DRAWN BY: J.B.LONG-HM 04-70	JOB No.: 04897	ACCT. NAME:
DATE: 12-30-04		POLYSIUS/ESSROC CEM
CHK'D BY: CEP	DWG No.:	
DATE: 1-13-05		F4
APPR'D BY: --	SHEET No.:	REVISION:
DATE: --	of . SHEETS	0
SCALE: --		